



PYROGREEN SOLAR

ALUMINIUM SOLAR PANEL FRAME



SOLAR PROFILES

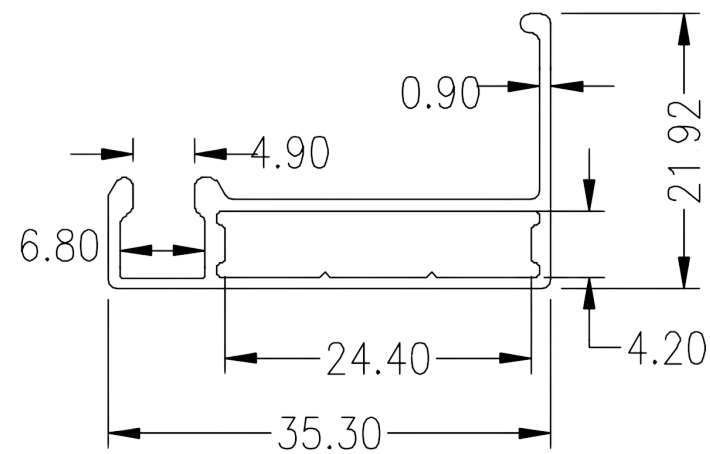

WEIGHT 0.491 KG/MT

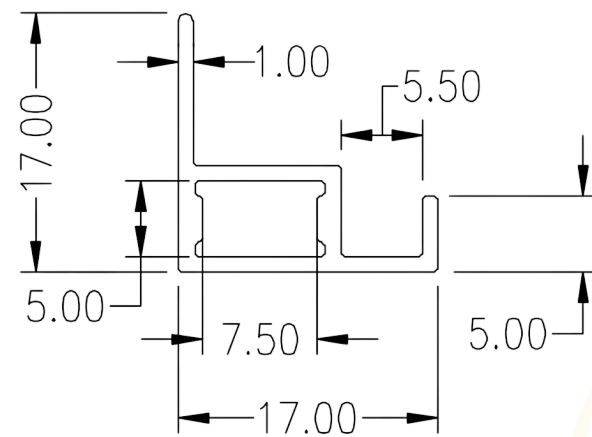

WEIGHT 0.170 KG/MT

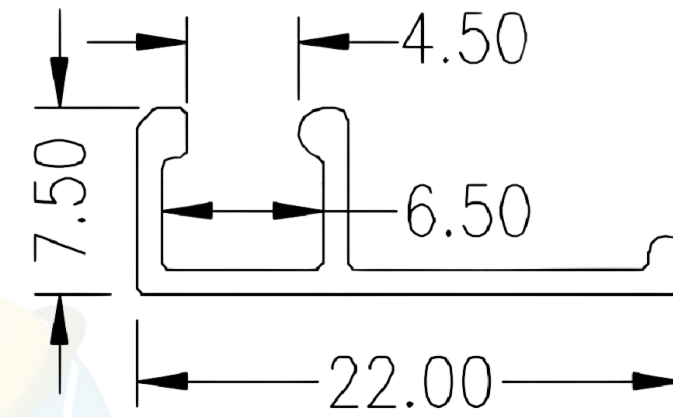

WEIGHT 0.128 KG/MT

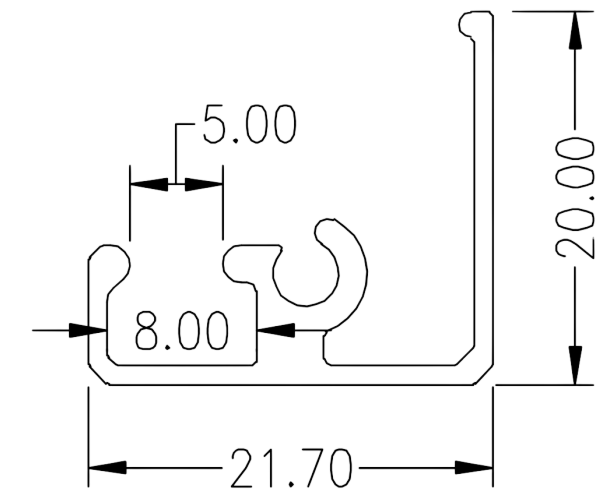

WEIGHT 0.231 KG/MT

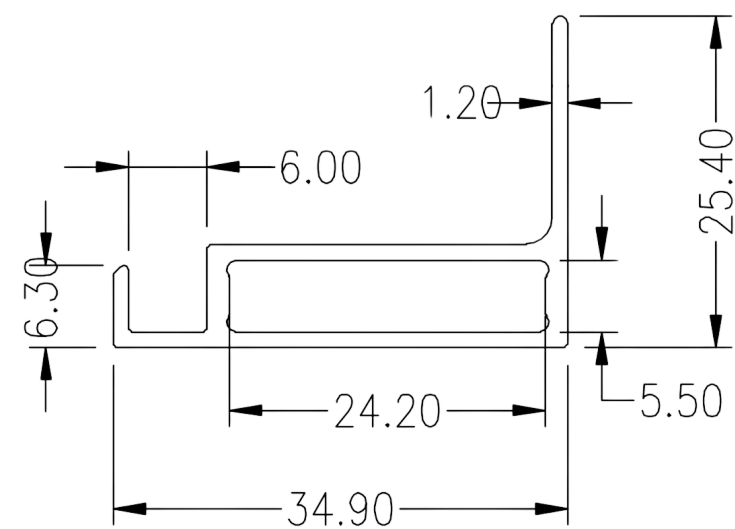

WEIGHT 0.347 KG/MT

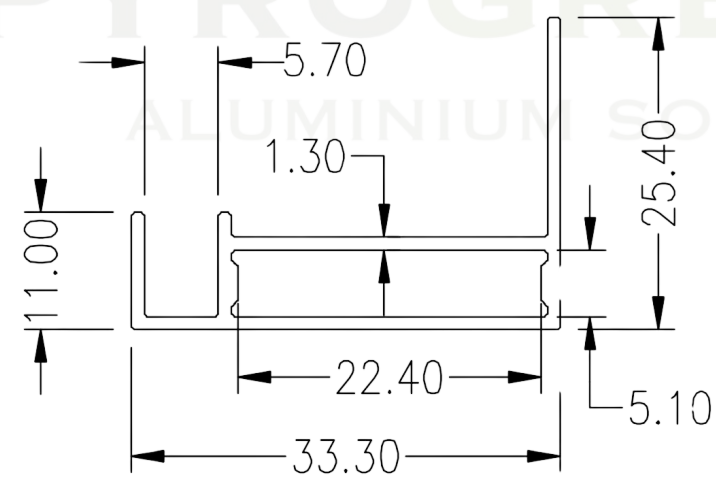

WEIGHT 0.491 KG/MT

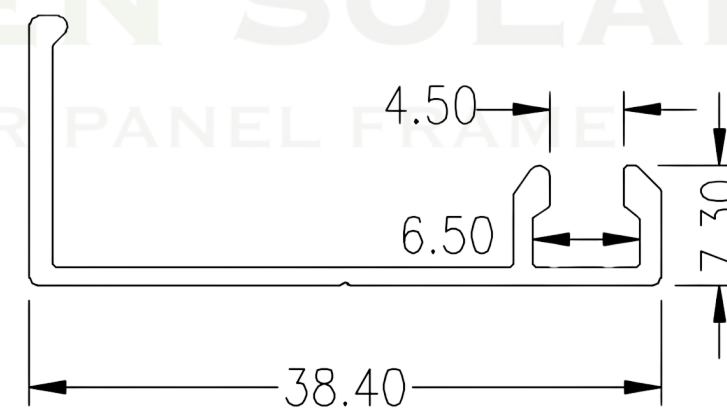

WEIGHT 0.246 KG/MT

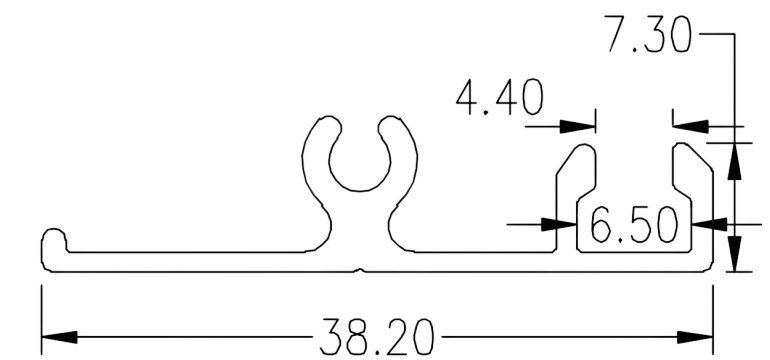

WEIGHT 0.262 KG/MT



SOLAR PROFILES

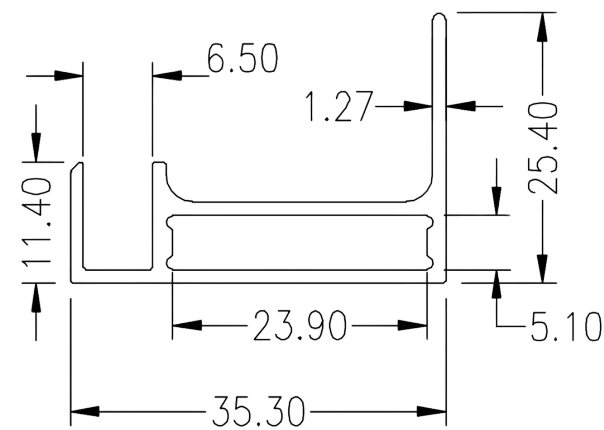

WEIGHT 0.444 KG/MT

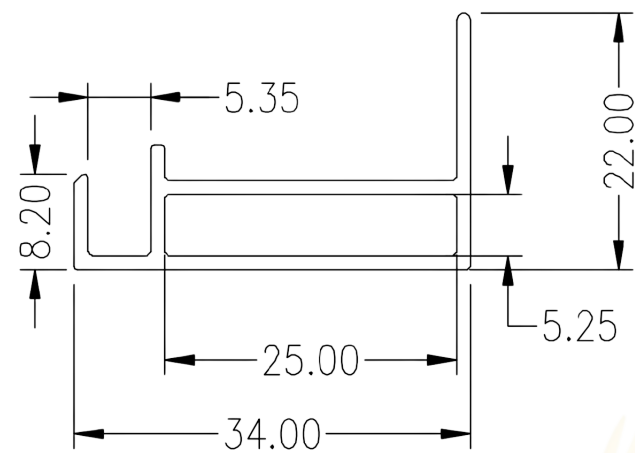

WEIGHT 0.311 KG/MT

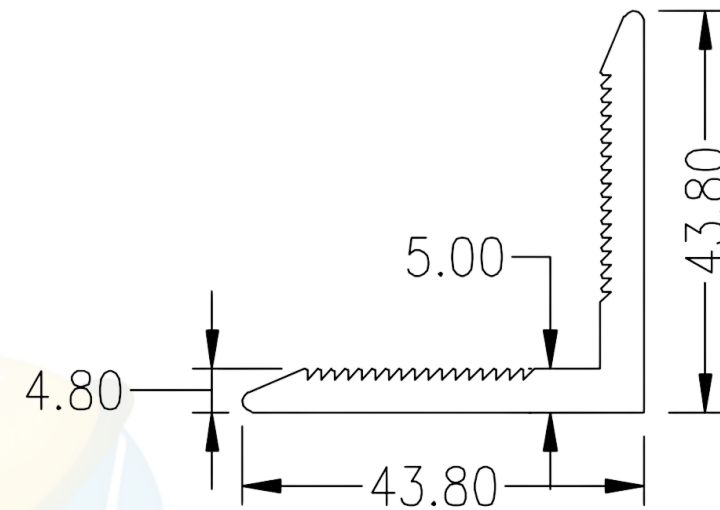

WEIGHT 0.795 KG/MT

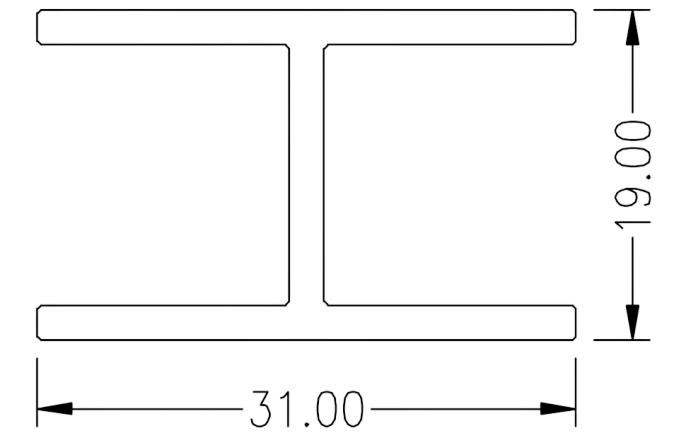

WEIGHT 0.425 KG/MT

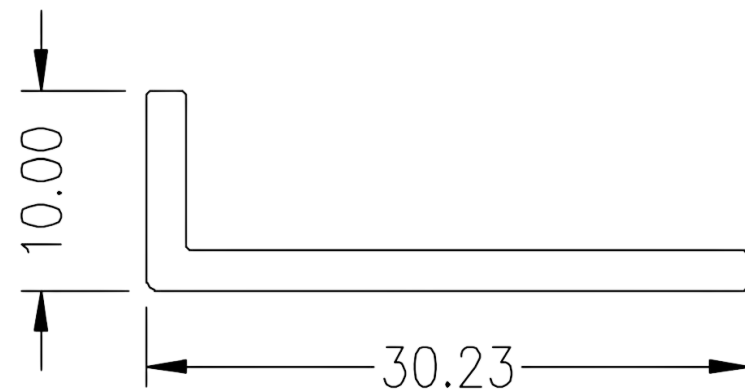

WEIGHT 0.210 KG/MT

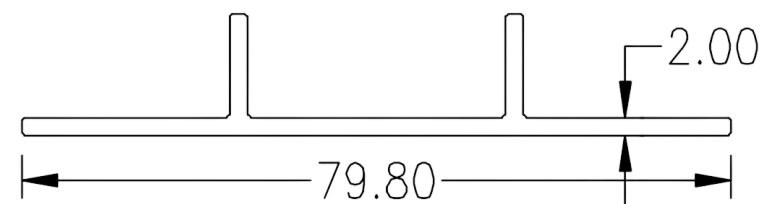

WEIGHT 0.557 KG/MT

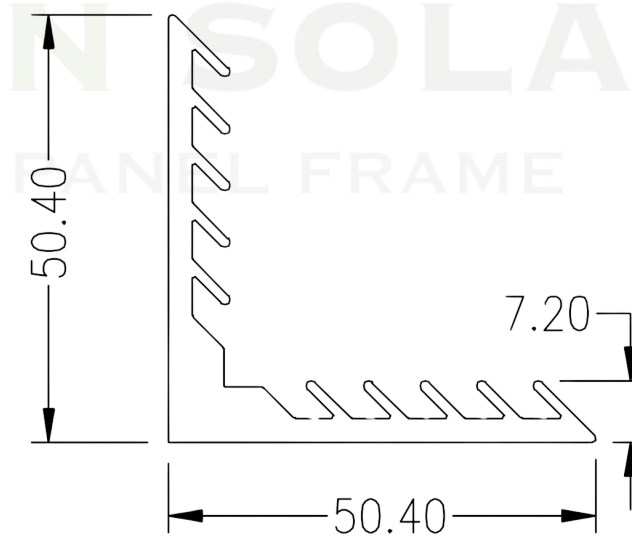

WEIGHT 1.105 KG/MT

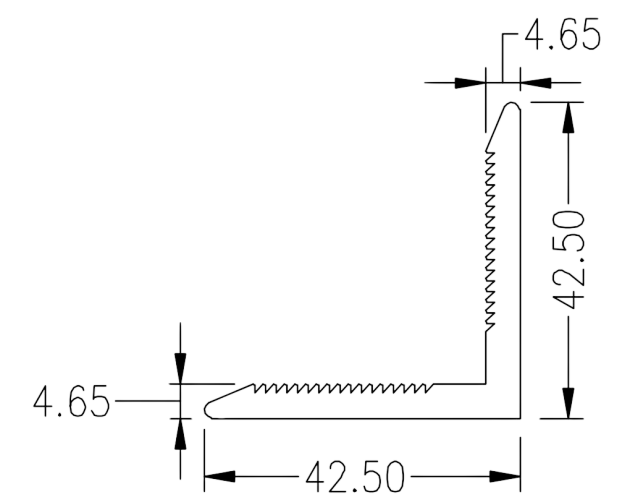

WEIGHT 0.665 KG/MT



SOLAR PROFILES

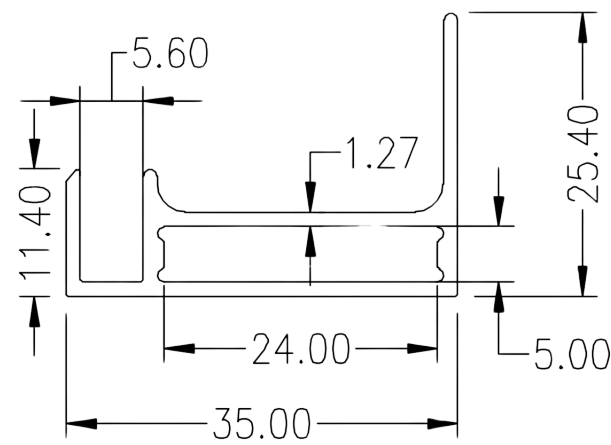

WEIGHT 0.400 KG/MT

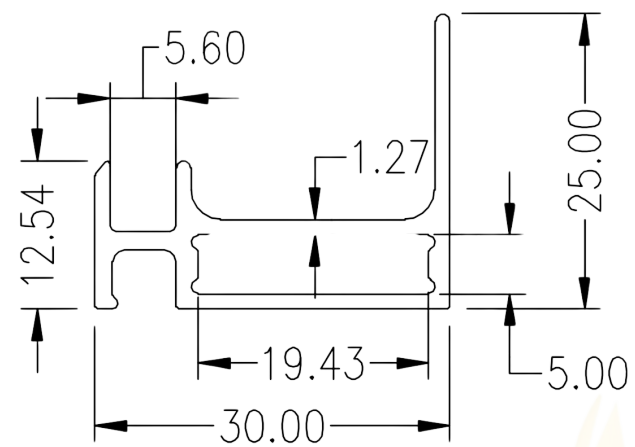

WEIGHT 0.376 KG/MT

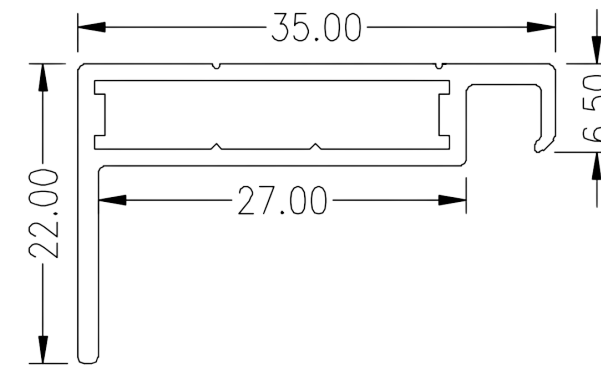

WEIGHT 0.356 KG/MT

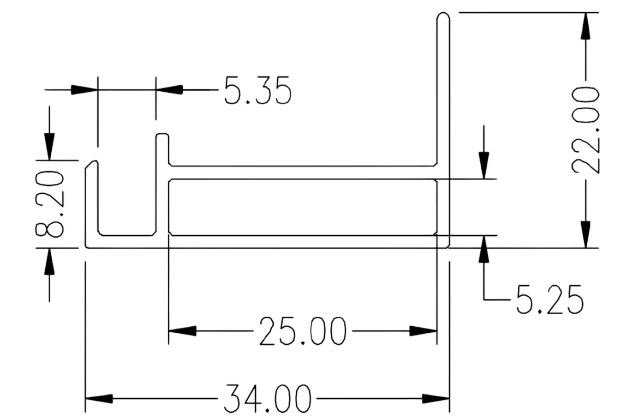

WEIGHT 0.273 KG/MT

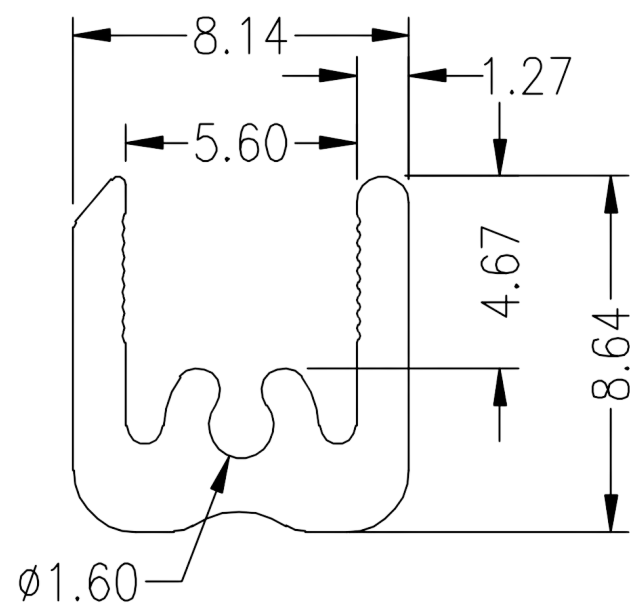

WEIGHT 0.557 KG/MT

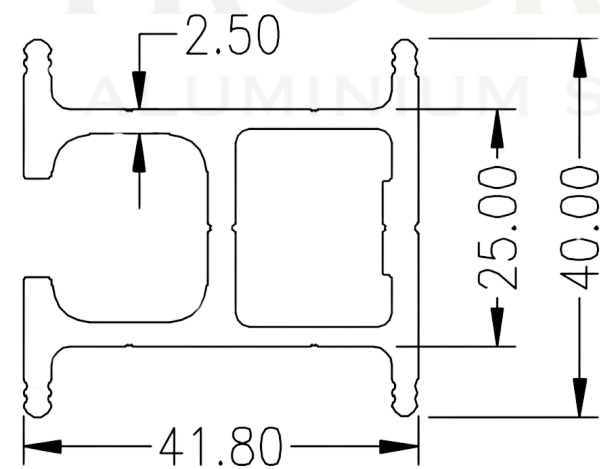

WEIGHT 1.220 KG/MT

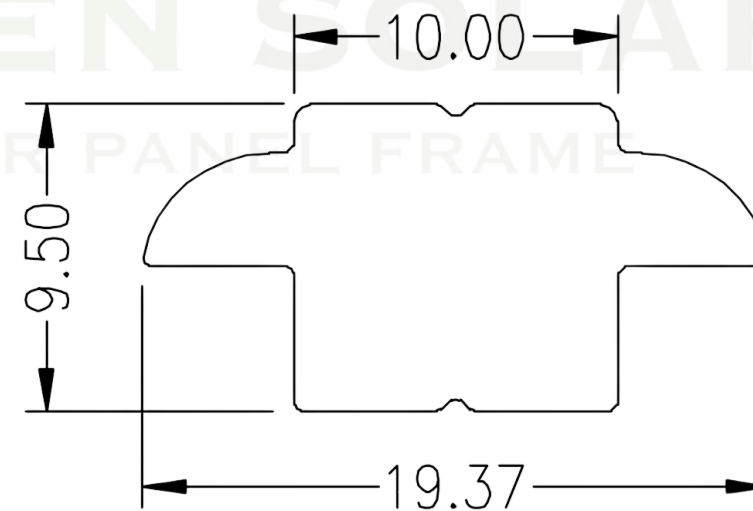

WEIGHT 0.375 KG/MT

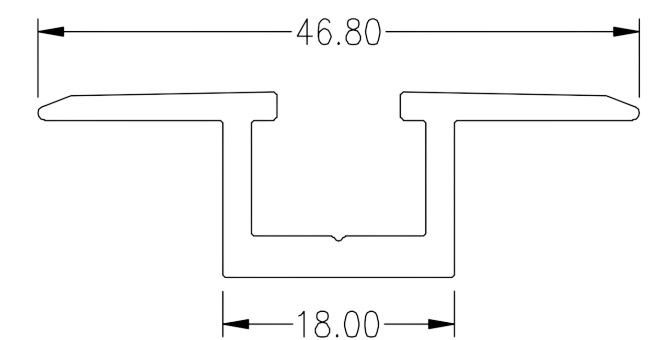

WEIGHT 1.105 KG/MT



SOLAR PROFILES

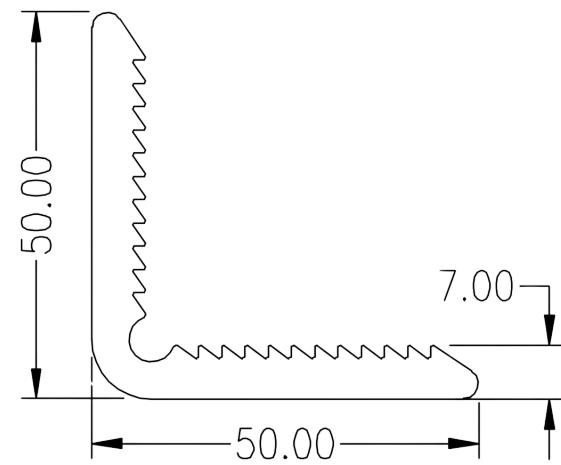

WEIGHT 0.376 KG/MT

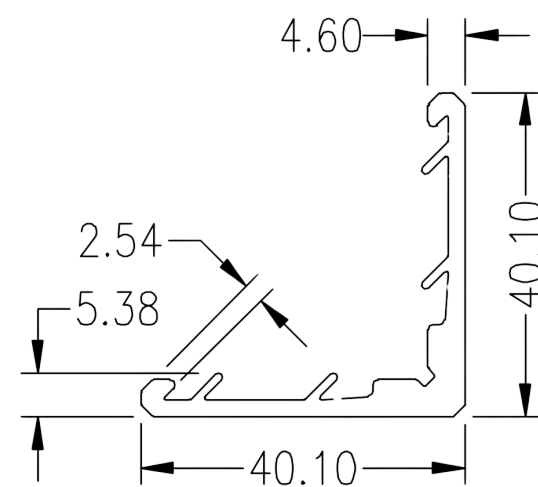

WEIGHT 0.665 KG/MT

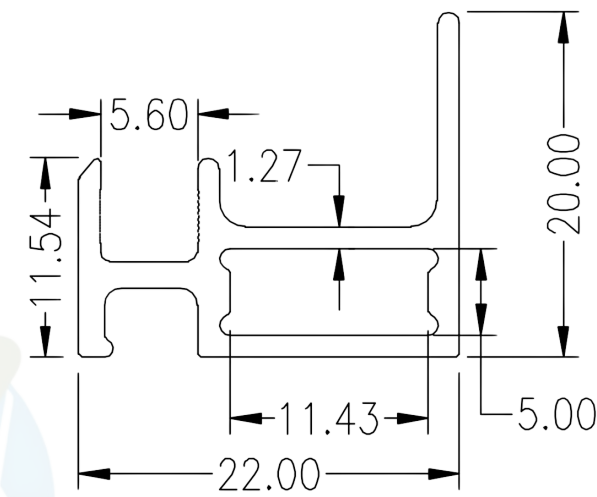

WEIGHT 0.291 KG/MT

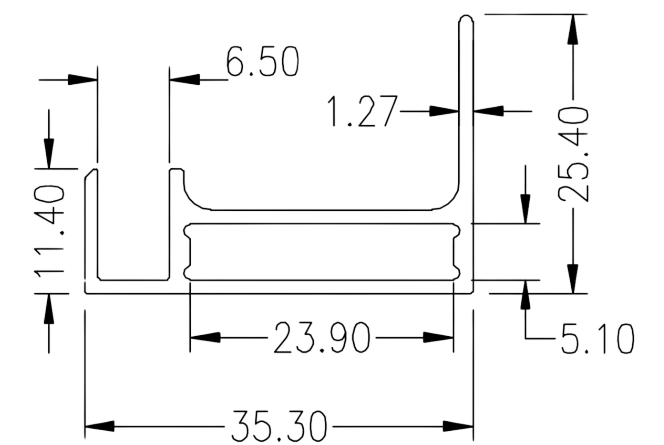

WEIGHT 0.400 KG/MT

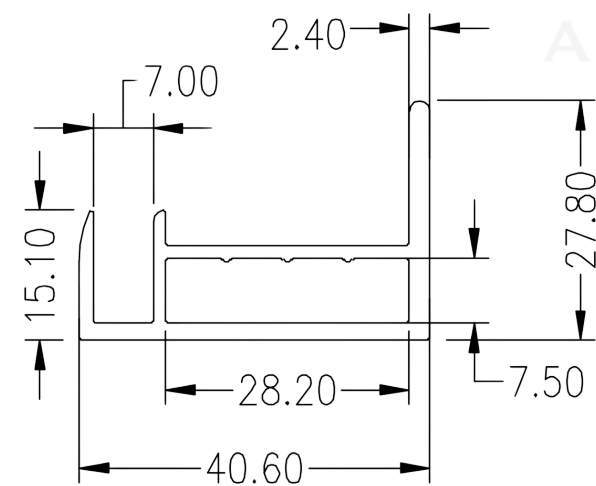

WEIGHT 0.610 KG/MT

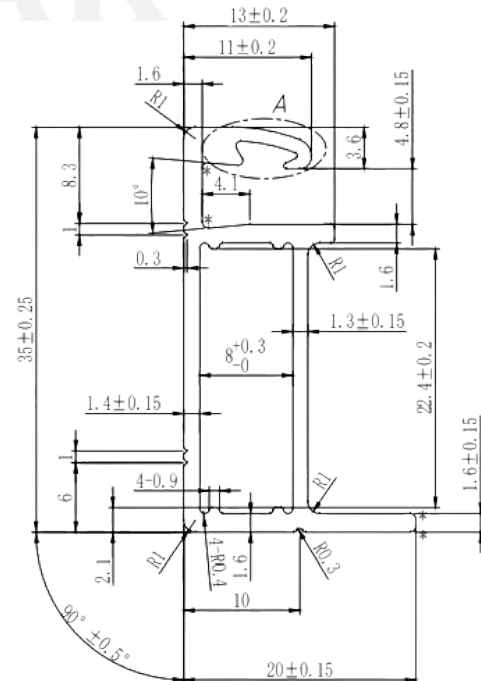
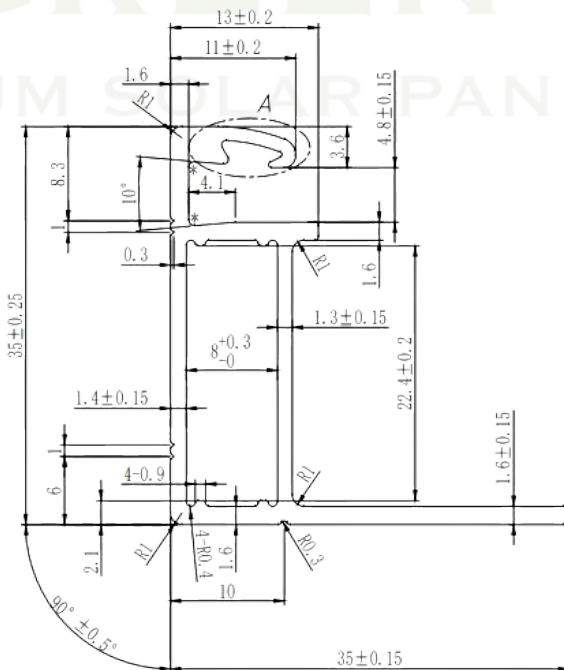



CORNER KEY

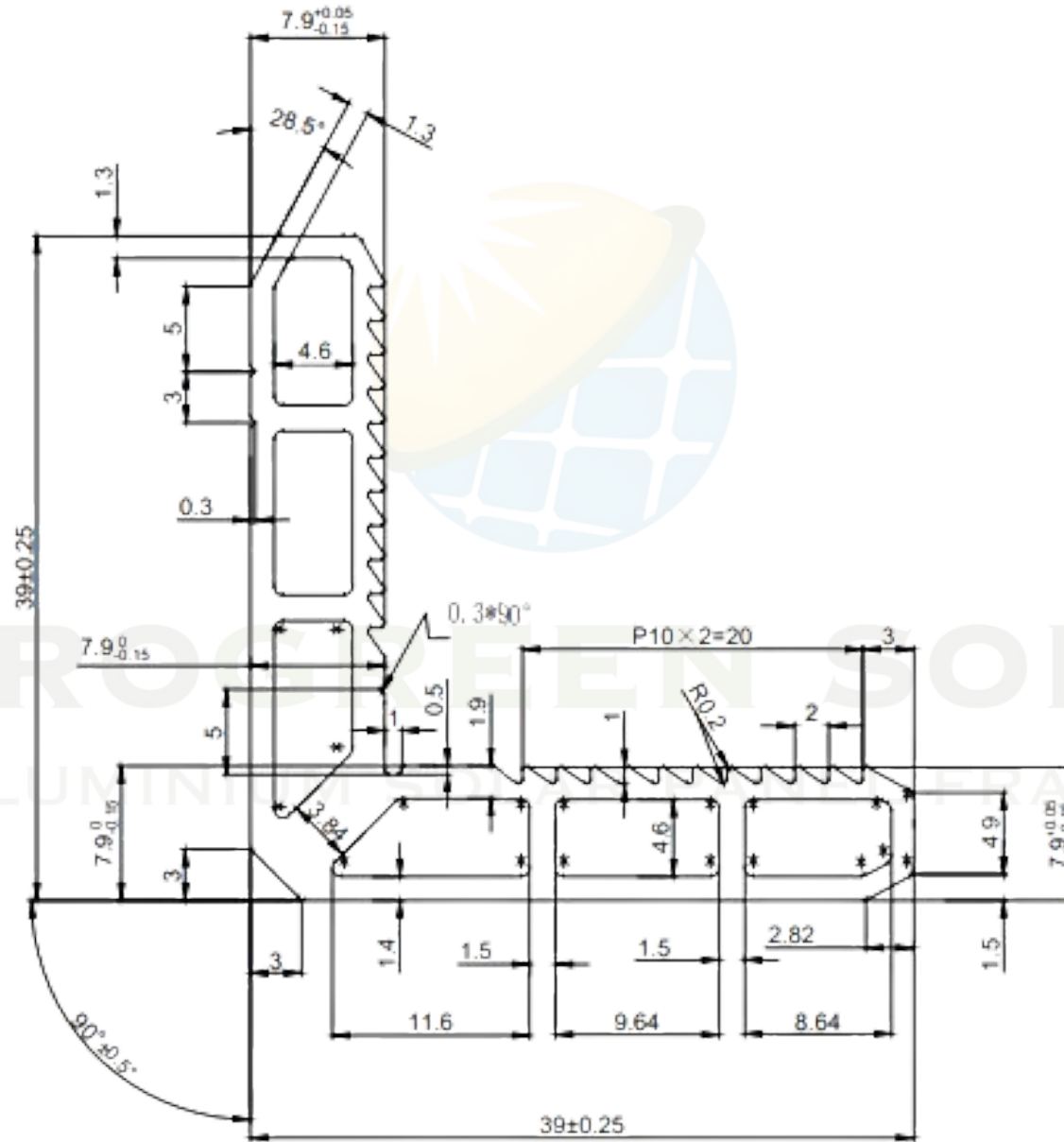



PYROGREEN SOLAR
ALUMINIUM SOLAR PANEL FRAME

FABRICATION

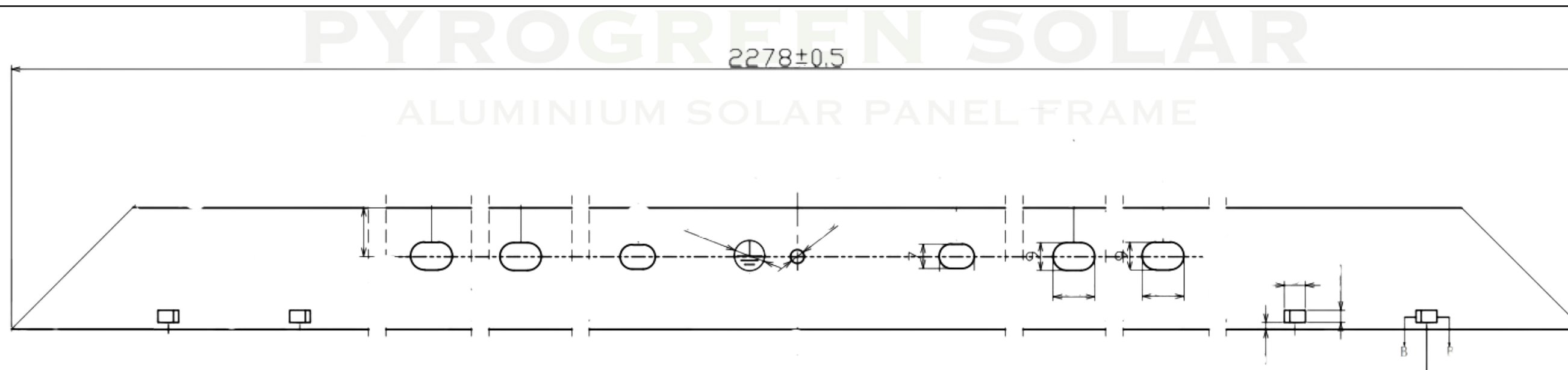
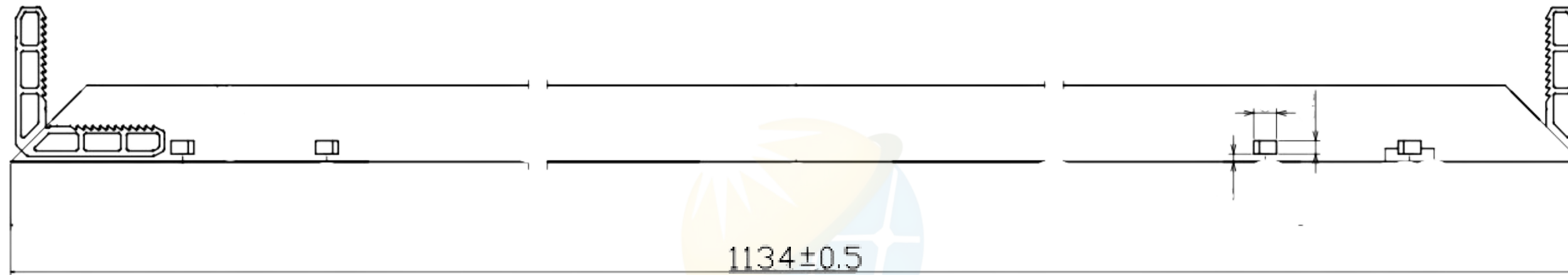



ANODIZING PROCESS

